

An Empirical Study of Employee Job Involvement and Personality Traits: The Case of Taiwan

CHI-SHUN LIAO^{a*} AND CHENG-WEN LEE^b

^a *Graduate Institute of Management, Chung Yuan Christian University,
200 Chung Pei Rd., Chung Li, Taiwan 32032, R.O.C.*

^b *Associate Professor, International Trade Department,
Chung Yuan Christian University,
200 Chung Pei Rd., Chung Li, Taiwan 32032, R.O.C.*

ABSTRACT

This study undertakes an integrated review of previous literature and theories regarding the Big Five personality traits and job involvement in an attempt to identify their relationship. Using questionnaire data gathered from 272 Taiwanese plastics industry employees, the study tests five hypotheses using structural equations. Empirical findings show that neuroticism relates negatively to employee job involvement, whereas extroversion, openness, agreeableness, and conscientiousness relate positively to it. These results may serve as a reference point for management and operations, particularly in plastics industry organizations.

Keywords: Job Involvement, Personality Traits, Workplace and Plastics Industry.

INTRODUCTION

Human behavior plays a significant role in maximizing organizational effectiveness, regardless of technological development. In particular, any effort to maximize organizational effectiveness requires a higher degree of job involvement (JI) among members of an organization (Elankumaran, 2004). That is, JI is an important motivational variable for any organization. In the modern economic era in particular, JI also contributes to the overall availability of human resources (Gore, 2001). For

* Corresponding author: Tel: 886-2-26298344, 886-972047161. Fax: 886-3-2655299. Email: naylor.shun@msa.hinet.net and Tel: 886-3-2655200, +886-935333837. Fax: 886-3-2655299. Email: chengwen@cycu.edu.tw

Any remaining errors or omissions rest solely with the author (s) of this paper.

highly involved employees, their jobs seem inexorably connected to their diverse identities, interests, and life goals, as well as the satisfaction that they can derive from performing their job duties effectively.

More involved persons also feel more competent and successful at work, believe that their personal and organizational goals are compatible, and tend to attribute positive work outcomes to their internal and personally controllable factors. However, because some people exhibit less variability in their efforts than others, it may be of interest for organizations to identify which employees, whether managers or supervisees, are more prone to variability in their responses.

Furthermore, organizations need to know how to achieve the highest degrees of JI or improve these levels. Although all organizations likely aspire to encourage a high degree of JI, this effort is extremely difficult, largely because of the inherent differences in the degrees of JI among employees. These differences may be due to variations in personality, a key individual difference variable. Thus, even though enriching individual dimensions might help solve behavioral problems and thereby contribute to organizational effectiveness (Elankumaran, 2004), human psychology studies continue to ignore this critical dimension.

The human personality dimension also might provide a means to determine why an employee appears more or less involved in work. With such information, managers could identify the kinds of personalities that best fit with specific job characteristics and avoid choosing inappropriate staff, as well as coordinate coordinating diverse employee activities to maximize productivity, efficiency, and effectiveness. A realistic view of JI thus suggests that it is a function of personality; this study in turn investigates the potential relationship between employee personalities and JI.

LITERATURE REVIEW AND HYPOTHESES

Personality Traits

Personal characteristics mainly describe and predict human behavior, not behavioral changes or development. Personal characteristics also indicate different characteristics that can contribute to inferences about behavioral results. The systemic classification of personal characteristics suggested by McDougall (1932) asserts that personality consists of five factors: intellect, character, temperament, disposition, and temper. Cattell (1943) proposed a more complicated classification with 16 main factors and 8 secondary factors. In their analysis of Cattell's approach, Tupes and Christal (1961) find that five factors (extroversion, neuroticism [emotional stability], agreeableness, conscientiousness, and culture) explain the classification, and their proposed factors match McDougall's views. More recently, Barrick and Mount's (1991) meta-analysis confirms the five factors that most researchers continue to use today: neuroticism (emotional stability), extroversion, openness, agreeableness, and conscientiousness.

These five factors have come to be known as the Big Five (Goldberg, 1990); they represent the most significant personal viewpoints across measurements, cultures, and evaluations (McCrae & John, 1992). The Big Five appear also in various psychological fields, especially those pertaining to work performance (Barrick & Mount, 1991). McCrae and Costa (1991) suggest further applications to consultations, education, forensic science, and health psychology.

This study investigates the relationship between each personality dimension and JI progressively, because the Big Five provide the best representation of a person's personality. In addition, because this classification is conscientious and includes extensive items, as proven by powerful real-world examples (Goldberg, 1993; O'Connor, 2002), the Big Five personality dimensions serve as the analysis variables for this research.

Job Involvement

Lodahl and Kejner (1965) define JI as the degree of daily absorption a worker experiences in his or her work activity; it reflects whether the person considers consciousness and work affirmation main foci. In addition, JI represents the extent to which a person's self-esteem depends on his or her work efficiency. These two dimensions – psychological identification with work and the importance of work productivity or efficiency to individual self-esteem – constitute the main theoretical conceptualization used in previous research.

Rabinowitz and Hall (1977) also argue that JI is an individual difference variable, whether primarily an attribute of the person or a response to the work environment. If JI is a stable attribute of a person, it is somewhat akin to a personality characteristic, such that JI represents the employee's response to the psychological stimulation that characterizes the job. However, if JI reflects the working environment and particular work characteristics, it requires consideration from the perspective of work organization and work design. Which variables have greater explanatory power when it comes to JI?

Rabinowitz, Hall and Goodale (1977) posit that personal and environmental variables are equally important, though Newton and Keenan (1983) indicate that environmental variables can better predict JI, whereas another study considers personal attributes more relevant (McKelvey & Sekaran, 1977). Thus, it appears that both personal attributes and work environment factors can explain JI. Overall, existing research assumes that higher JI is an inherently desirable attribute of employees (Mudrack, 2004). In this sense, when examining and explaining the relationships between JI and other key variables, the psychological identification dimension may hold the most interest. In line with previous definitions of JI – as the degree to which people identify psychologically with their jobs or the psychological importance of the work to the person – this study operationally defines JI as the importance of work efficiency to an employee.

Personality Traits and Job Involvement

Neurotic (Emotionally Stable) Personality

Meta-analyses suggest that emotional stability prompts greater job proficiency across occupations (Clarke and Robertson, 2005), whereas neuroticism should be associated with lower job efficiency. A neurotic personality experiences anxiety, depression, anger, insecurity, and worry (Barrick and Mount, 1991), which tend to create negative opinions. A neurotic employee probably does not have positive attitudes toward work and may lack of confidence and optimism, which should result in less ambition and less focus on career goals. Therefore, a negative relationship likely exists between neuroticism and goal direction (Malouff *et al.*, 1990), such that low goal trends should be due to low work efficiency.

Neurotic employees also are less likely to devote themselves to work and more likely to be distracted easily, which increases their behavioral risks and suggests a positive relationship between insufficient work efficiency and neuroticism. In addition, when a person possesses high neuroticism, he or she likely considers feedback a type of threat that produces anxiety and overly intense stimuli (Smither, London and Richmond, 2005).

Smithikrai (2007) indicates that neuroticism has a significant negative correlation with job success; in the future, neurotic employees may be even less productive at work as globalization and technological advances induce changes in organizational life. Niehoff (2006) notes also that neuroticism appears consistently negatively correlated with leadership emergence and effectiveness. Thus, the neuroticism dimension should be able to predict task-based criteria, such as quantity and quality of work. According to deductive reasoning then, neuroticism should correlate negatively with JI.

Hypothesis 1: Employees characterized by high neuroticism experience low job involvement.

Extroverted Personality

Extraversion is a prominent factor in personality psychology, as evidenced by its appearance in most personality measures and its important role in the major taxonomies of personality (Judge *et al.*, 1999). An extroverted personality tends to be sociable, assertive, gregarious, talkative, and ambitious (Cooper, 2003), so such people often use their working environment to represent a key facet of their lives that enables them to meet their aspirations and exhibit their talents (Hurley, 1998).

Highly extroverted employees likely use their stable, cool-headed, optimistic, and aggressive manner to react to customers' requests, which results in work completion and customer satisfaction. Varca (2004) predicts that when a person is

highly extroverted, he or she usually provides services ahead of time. Smithikrai (2007) finds a positive relationship between extraversion and job success, especially in jobs that require interpersonal contacts. Another explanation for the relationship between extraversion and JI posits that extroverted employees make better use of their competencies than do employees with low extraversion, which enables them to increase their self-efficacy, which in turn leads to better work efficacy (Berg and Feij, 2003). Considering these results and recent analyses of work efficacy for project work, an extroverted disposition appears recommended as critical for advancing JI.

Hypothesis 2: Employees characterized by high extroversion exhibit high job involvement.

Openness Personality

Openness, one of the least studied of the Big Five personality dimensions in terms of job behavior, includes the ability to be imaginative, unconventional, curious, broadminded, and cultured (Clarke and Robertson, 2005). High openness may prompt job efficiency, because work enables these employees to satisfy their curiosity, explore new viewpoints, and develop real interests in their activities. Therefore, they likely *distinguish important work activities and combine their* observations with appropriate behavior to develop a work method that maximizes productivity, efficiency, and effectiveness. Moreover, as work fields expand and technological changes proliferate, there is likely to be greater demand for productive workers who are aware of new developments and engage in continuing education and professional growth, which may increase the importance of openness for ensuring positive work efficiency (Lounsbury *et al.*, 2007).

Openness to experience also suggests an attraction to new ideas, concepts, actions, or feelings (Niehoff, 2006). Persons with higher levels of openness likely achieve greater efficiency at work, because they pursue opportunities to learn new perspectives and deal with ambiguous situations. Furthermore, an employee with an open personality should tend to be task-based, constantly searching for new methods to complete his or her work (Stewart and Nandkeolyar, 2006), which again should strengthen working efficiency.

Hypothesis 3: Employees characterized by high openness exhibit high job involvement.

Agreeable Personality

The agreeableness personality dimension suggests a courteous, flexible, trusting, good-natured, cooperative, forgiving, soft-hearted, tolerant person (Cooper, 2003). Agreeable employees consider personal interactions carefully, such that they

offer more constructive responses to customers and to their work. In addition, agreeableness can push staff members to work together, which should result in effective working behaviors (Barrick and Mount, 1991). In turn, a highly agreeable employee likely develops positive perceptions of work efficiency.

Because they tend to regard work and career achievement as in keeping with their desire to improve their personal value and earn respect, agreeable employees should be more involved in their jobs. When interacting and cooperating with others, agreeable employees also achieve better effects (Barrick and Mount, 1991), which likely increases work efficiency.

Finally, agreeable employees are cooperative and forgiving, tend to follow rules, and act courteously to get ahead. High agreeableness therefore has critical implications for understanding service-based productive behavior and efficiency. In this sense, agreeableness provides a valid predictor of criteria that pertain to customer (Mount and Ilies, 2006), because agreeable persons are more concerned with others' welfare (Ashton and Lee, 2001). The importance of customer service as a valued attribute of workers appears likely to increase in the future, considering the multiple internal customers that modern employees must serve, such as marketing and sales departments, as well as the push toward an ever-increasing integration of work with other organizational functions (Lounsbury *et al.*, 2007). Consequently, agreeableness should be positively related to JI.

Hypothesis 4: Employees characterized by high agreeableness exhibit high job involvement.

Conscientious Personality

Competence, order, dutifulness, achievement striving, self-discipline, and deliberation constitute the conscientiousness personality dimension. Although conscientiousness is task-based, it emphasizes goal achievement. The employee recognizes the importance of reaching a goal and expends energetic, long-suffering, and untiring efforts (Burch and Anderson, 2004) to obtain satisfaction from performing the duty effectively. Low conscientiousness instead suggests the employee tries to meet only immediate demands, does not care about prospective results, lacks a sense of goals, mistakenly observes rules (Arthur and Doverspike, 2001) or standards, and performs tasks poorly (Wallace and Vodanovich, 2003). A conscientious employee likely attains greater job efficiency, which should improve JI.

Smithikrai (2007) posits a positive relationship between conscientiousness and job success, because conscientious persons tend to work toward their goals in an industrious manner. These employees are more likely to believe that their work has special meaning, and thus, they experience greater psychological attachment to their jobs (Li, Lin & Chen, 2007). They also regulate their work behavior more effectively

(Wallace & Chen, 2006). Judge and Ilies (2002) reveal that conscientiousness is instrumental to people's work success, as well as their motivation to get along and their desire to be productive. Those high in conscientiousness exhibit the capacity to function or develop in generally productive ways and can accomplish more work more quickly. Thus, a conscientious orientation should correlate positively with JI.

Hypothesis 5: Employees characterized by high conscientiousness exhibit high job involvement.

METHOD

Sample and Procedures

The research population consists of small- and medium-sized enterprises (SMEs) in the plastics industry in Taiwan. Such firms have made remarkable contributions to Taiwan's development, such that in 2008, annual sales volume of SMEs constitutes 28.34% of the national industrial production volume, as well as 17.2% of national export trade. With regard to national industry and commerce levels, SMEs total approximately 98%, and they employ 77.12% of the total employed population of Taiwan (Small and Medium Enterprise Administration, 2008).

This significance means that the efficiency of employees of SMEs is closely interwoven with the overall society and development of Taiwan. Furthermore, studying the personality traits – job involvement relationship in a single industry across different institutional environments provides some control over extraneous variables. This research approach therefore tests the extent to which the findings reflect employee choice, which can help identify current conditions and predict future human resource planning for domestic SMEs. To explore empirically how Taiwan's executives perceive the relationship between personality traits and JI and its effect on their operations, this study conducts a survey among members of the Plastic Industrial Association. The mail survey addresses a total of 625 companies that represent a wide variety of plastic industries.

The research investigators received training, including explanations of the questionnaire and the investigation methods, to ensure the validity of the questionnaire retrieval. The initial mailing of 625 questionnaires produced 286 responses, though elimination of incomplete or invalid responses left an effective sample of 272, for a 43.5% response rate. The respondent demographics indicate that 42% of the respondents are women and 58% are men, mostly aged between 35 and 44 years. The most common level of education they achieved was junior high school or lower (47.8%), and most of these respondents are front-line employees. Table 1 further specifies the distribution of participants' characteristics.

Table 1 Participant characteristics

	Number	(%)
Gender		
Male	158	58.0
Female	114	42.0
Age		
Under 24	8	2.9
25-29	15	5.5
30-34	34	12.5
35-39	80	29.4
40-44	92	33.8
45-49	32	11.8
50-54	7	2.6
Over 55	4	1.5
Education level		
Junior high school or below	130	47.8
Specialized school	59	21.7
College	74	27.2
Graduate school or beyond	9	3.3
Position		
Operator	41	15.1
Officer/ Assistant	76	27.9
Engineer	55	20.2
Ganger	67	24.6
Other	33	12.2
Position tenure		
Under 5 years	9	3.3
6-15years	162	59.6
16-25 years	90	33.1
Over 26 years	11	4.0

Measures

The measure of JI is a modified version of Lodahl and Kejner's (1965) JI scale. The operational measures describe JI as "internalization of values about the goodness of work" and "the degree to which a person's work is worthwhile." The five items suggested by Lodahl and Kejner also measure a sense of duty toward work and an expectation of work efficiency. The NEO Personality Inventory (Costa & McCrae, 1992) serves to assess the Big Five personality traits. Each scale item relies on a five-point scale Likert scale (1 = strongly disagree, 5 = strongly agree). A confirmatory factor analysis (CFA) determines correlations among the personality traits, and popular maximum likelihood estimation techniques test the model.

Reliability and Validity

To assess the validity and unidimensionality of the scale, this study employs CFA (Joreskog & Sorbom, 1993), whereas the assessment of convergent validity relies on *t*-tests for the factor loadings (Hatcher, 1994). The CFA results confirm convergent validity (all *t*-values exceed 1.65 at $p = .05$) and show that each factor is a unidimensional construct. The Cronbach's alphas for neuroticism, extroversion, openness, agreeableness, conscientiousness, and JI are .85, .81, .90, .84, .72, and .89, respectively, which indicate high reliability. Thus, the model appears to achieve adequate reliability and convergent validity.

ANALYSIS AND RESULTS

Descriptive Statistics

Correlation analysis investigates the relationships among the variables simultaneously and produces a correlation matrix that clarifies the relationship patterns for the personality traits and job involvement (Table 2).

Table 2 Correlation matrix

Variables	1	2	3	4	5	6
Neuroticism	1.000					
Extroversion	-0.510	1.000				
Openness	-0.023	0.428	1.000			
Agreeableness	-0.479	0.454	0.001	1.000		
Conscientiousness	-0.039	0.448	0.151	0.081	1.000	
Job Involvement	-0.632	0.529	0.016	0.085	0.386	1.000

Notes: Bold cells indicate $p < .05$.

Model Analysis

The results of the hypotheses testing in Table 3 confirm the proposed relationships. All hypotheses are significant, and all model fitness indexes pass their respective evaluation criteria. Specifically, the Big Five personality traits have significant effects on job involvement: Neuroticism has a significant negative effect on job involvement ($\gamma^{sub 11} = -.80, p < .01$), in support of H1. Extroversion is positively associated with JI, in support of H2 ($\gamma^{sub 12} = .78, p < .05$). Openness also is significantly associated with an increase in job involvement ($\gamma^{sub 13} = .85, p < .01$), in support of H3. The respondents tend to associate greater agreeableness with a higher level of JI ($\gamma^{sub 14} = .62, p < .01$), in support of H4. Finally, conscientiousness relates positively to a high level of JI ($\gamma^{sub 15} = .91, p < .05$), in support of H5. In summary, the Big Five personality dimensions indicate significant positive influences on JI, with the exception of neuroticism, which has significant negative effect.

Table 3 Structural equation modeling estimation results

Path	Estimate	t Value	Hypothesis Results
H1: Neuroticism => Negative job involvement	-0.80	-7.69**	Support
H2: Extroversion => Positive job involvement	0.78	2.12*	Support
H3: Openness => Positive job involvement	0.85	6.27*	Support
H4: Agreeableness => Positive job involvement	0.62	4.8**	Support
H5: Conscientiousness => Positive job involvement	0.91	1.73*	Support

* $p < 0.05$. ** $p < 0.01$.

As the path diagram in Figure 1 shows, five indicator variables each are available for the neuroticism (X1, X2, X3, X4, and X5) and conscientiousness (X18, X19, X20, X21, and X22) constructs. Four indicator variables each provide the principal descriptors of the extroversion (X6, X7, X8, and X9), openness (X10, X11, X12, and X13), and agreeableness (X14, X15, X16, and X17) dimensions. For one of the endogenous constructs, job involvement, five indicator variables (Y1, Y2, Y3, Y4, and Y5) are available, constructed by summing the five JI measures. The results show that all standardized loadings are greater than .60; that is, all loadings are moderately large. The measurement model provides a good fit to the data: ($\chi^2(362) = 1816.19$, goodness-of-fit index [GFI] = .93, confirmatory fit index [CFI] = .98, root mean squared error of approximation [RMSEA] = .07).

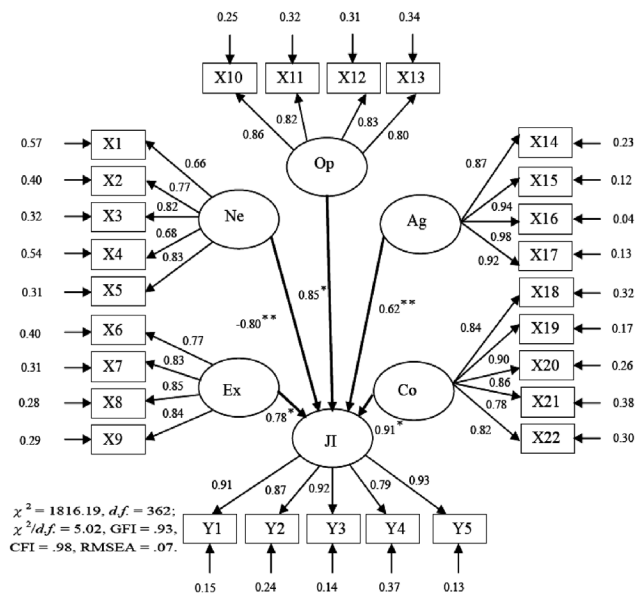

Figure 1 SEM results

Overall, the model fit measures exhibit the excellent conformance of the data to the model. The χ^2 for the goodness of fit is 1816.19, based on 362 degrees of freedom. The RMSEA of .07 is below the .08 cut-off value suggested by Browne and Cudeck (1993). In addition, the GFI falls above the commonly recommended .90 limit (Lichtenstein and Ridgway, 1993), as does the CFI value, providing further evidence of good fit.

DISCUSSION AND CONCLUSION

This article proposes several specific relationships between the Big Five personality dimensions and JI, adapted from reviews of relevant psychology research, in application to a real sample. It also investigates the reciprocal effect of the Big Five and JI. The results indicate that personality dimensions help determine employees' JI, so when an organization recruits new staff or attempts to encourage existing staff members to work together, managers should recognize the relevant personality dimensions and use the likely predicted level of efficiency and restrictions to assess and develop effective encouragements.

By investigating the influence of the Big Five personality dimensions on JI, this study confirms that neuroticism relates negatively to JI, such that a neurotic employee is less efficient in his or her work. However, extroversion, openness, agreeableness, and conscientiousness all relate positively to JI.

The significant relations between the two sets of variables also suggest some positive benefits of an employee's JI in the workplace (Costa and McCrae, 1992; Hurley, Knudstrup and Segrest, 2003; Organ and Lingl, 1995). According to the data presented herein, an employee with higher extroversion, openness, agreeableness, and conscientiousness tends to exhibit high levels of sociability, dutifulness, cooperation, broadmindedness, performance, and career goals, which lead to positive relationships with JI. Therefore, when a manager assesses the degree of staff JI, he or she should address not only environmental impact factors but also employee personalities to ensure the effective and efficient achievement of work goals.

The study results also can contribute to understand work behaviors by employees in Taiwan. Because employees with greater work involvement tend to expend more mental and physical effort during their working hours, and the core of their lives mostly focuses on their jobs, their turnover tendency should be lower. Employees with high neuroticism instead engage in inattentive behaviors, such as careless errors, failing to follow working norms, or producing ignorant mistakes. Employees with high extraversion get along well with colleagues and customers, and they likely will inquire about anything that they do not understand immediately and actively. Therefore, the work performance of this kind of employees should be better, which in turn increases their work satisfaction. Employees with high openness are task-oriented; because they look for new methods to complete their

tasks and strengthen their job performance, these employees could reach task enlightenment. Employees with high agreeableness are affable and easy to get along with, want to please others and engage in interpersonal interaction, and can easily undertake joint productions and cooperative behavior. Finally, because conscientious employees need to reach their set goals, they often spend significant time devoted to their job and training, which ensures their high professionalism. They likely can assimilate well with their colleagues and produce standardized behavior.

This study in turn offers several practical implications. For example, organizations should establish a mechanism to identify the various aspects of personality. Because JI depends significantly on employees' behaviors and responses, organizations can predict JI on the basis of other employee behaviors and responses. An employee who exhibits high JI achieves satisfaction through work efficiency, because he or she has positive feelings toward the work, is willing to commit to the organization, and expects to stay with the organization. Such an employee also is optimistic about the organization's future. By exploring the nature of the relationships between JI and the Big Five personality dimensions, this study helps link two bodies of research whose connections heretofore have remained unexplored. In turn, it provides greater insights into the phenomena considered in both job involvement and personality literature.

LIMITATIONS AND FURTHER RESEARCH

This study relies on a single industry and self-reported measurements, so the results should be interpreted with caution, especially with respect to causality. This study also does not entail specific work context, which could be a focus of further research. Because the investigated relationship between JI and internal motives suggests that highly involved employees transform internally and come to identify with their work, it may be that such employees become totally blended in with their activity and exhibit great enthusiasm. Therefore, the relationship between JI and internal motives might be even more clearly distinguished in additional research.

In addition to the Big Five personality dimensions and JI, other variables potentially moderate the relationship, including sex, age, experience, internalization of values, culture, and power sources. Other situational variables, such as the complexity of the work and organizational climate, also might interfere with the reciprocal effect. This study has proposed five relationships based on theoretical logic; however, when applying them to an actual enterprise, managers should consider which kind of reciprocal effect is most accurate, how to improve it, and any potential restrictions. The results of this study also can help managers design surveys that distinguish staff characteristics and address JI and work satisfaction to improve these process and induce internal motivation.

REFERENCES

- Arthur, W. and Doverspike, D. (2001) Predicting motor vehicle crash involvement from a personality measure and a driving knowledge test, *Journal of Prevention and Intervention in the Community*, **22**, 35 – 42.
- Ashton, M.C. and Lee, K. (2001) A theoretical basis for the major dimensions of personality, *European Journal of Personality*, **15**, 327 – 353.
- Barrick, M.R. and Mount, M.K. (1991) The Big Five personality dimensions and job performance: A Meta-analysis, *Personnel Psychology*, **44**, 1 – 26.
- Berg, P.T. van den and Feij, J.A. (2003) Complex Relationships Among Personality Traits, Job Characteristics, and Work Behaviors, *Internal Journal of Selection and Assessment*, **11**, 326 – 339.
- Browne, M. and Cudeck, R. (1993) *Alternative ways in assessing model fit*, in Bollen, K. and Long, S. (Eds), *Testing Structural Equation Models*, Sage Publications, Newbury Park, CA.
- Burch, G.S.J. and Anderson, N. (2004) Measuring person-team fit: Development and validation of the team selection inventory, *Journal of Managerial Psychology*, **19**, 406 – 426.
- Cattell R.B. (1943) The description of personality: Basic traits resolved into clusters, *Journal of Abnormal Social Psychology*, **38**, 476 – 506.
- Clarke, S. and Robertson, I.T. (2005) A meta-analytic review of the Big Five personality factors and accident involvement in occupational and nonoccupational settings, *Journal of Occupational and Organizational Psychology*, **78**, 355 – 376.
- Cooper, D. (2003) Psychology, risk and safety, *Professional Safety*, **48**, 39 – 46.
- Costa, P.T. Jr. and McCrae, R.R. (1992) *Revised NEO Personality Inventory (NEO-PI-R) and NEO Five-Factor (NEO-FFI) Inventory professional manual*, Odessa, FL: PAR.
- Elankumaran, S. (2004) Personality, organizational climate and job involvement: An empirical study, *Journal of Human Values*, **10**, 117 – 130.
- Goldberg, L.R. (1990) An alternative description of personality: The Big-Five factor structure, *Journal of Personality and Social Psychology*, **59**, 1216 – 1229.
- Goldberg, L.R. (1993) The structure of phenotypic personality traits, *American Psychologist*, **48**, 26 – 34.
- Gore, N. (2001) What's all this mobilizing about, *Canadian HR Reporter*, **14**, 17-19.
- Hatcher, L. (1994) *A step-by-step approach to using the SAS system for factor analysis and structural equation modeling*, Cary, N.C.: SAS Institute.
- Hurley, R.F. (1998) A customer service behavior in retail settings: A study of the effect of service provider personality, *Journal of the Academy of Marketing Sciences*, **26**, 115 – 227.
- Hurley A.E., Knudstrup, M. and Segrest, S.L. (2003) The use of mental imagery in the simulated employment interview situation, *Journal of Managerial Psychology*, **18**, 573 – 591.

- Joreskog, K. and Sorbom, D. (1993) *LISREL8: Structural equation modeling with the SIMPLIS command language*, Scientific Software, Chicago, IL.
- Judge, T.A., Higgins, C.A., Thoresen, C.J. and Barrick, M.R. (1999) The Big Five personality traits, general mental ability, and career success across the life span, *Personnel Psychology*, **52**, 621 – 652.
- Judge T.A. and Ilies, R. (2002) Relationship of personality to performance motivation: A meta-analytic review, *Journal of Applied Psychology*, **87**, 797 – 807.
- Karl, K.A., Peluchette, J.V. and Harland, L. (2007) Is fun for everyone?: Personality differences in healthcare providers' attitudes toward fun, *Journal of Health and Human Services Administration*, **29**, 409 – 447.
- Li, I-chuan, Lin, Mei-Chih and Chen, Ching-Min (2007) Relationship between personality traits, job satisfaction, and job involvement among Taiwanese community health volunteers, *Public Health Nursing*, **24**, 274 – 282.
- Lichtenstein, D. and Ridgway, N. (1993) Price perceptions and consumer shopping behavior: a field study, *Journal of Marketing Research*, **30**, 234 – 245.
- Lodahl, T.M. and Kejner, M. (1965) The definition and measurement of job involvement, *Journal of Applied Psychology*, **49**, 24 – 33.
- Lounsbury, J.W., Moffitt, L., Gibson, L.W., Drost, A.W. and Stevenson, M.W. (2007) An investigation of personality traits in relation to the job and career satisfaction of information technology professionals, *Journal of Information Technology*, **22**, 174 – 183.
- Malouff, J., Schutte, N., Bauer, M., Mantelli, D., Pierce, B., Cordova, G. and Schutte, E.R. (1990) Development and evaluation of a measure of the tendency to be goal-oriented, *Personality and Individual Differences*, **11**, 1191 – 1200.
- McCrae, R.R. and Costa, P.T. Jr. (1991) The NEO Personality Inventory: Using the Five-Factor model in counseling, *Journal of Counseling and Development*, **69**, 367 – 372.
- McCrae, R.R. and John, O.P. (1992) An introduction to the Five-Factor model and its applications, *Journal of Personality*, **2**, 175 – 215.
- McDougall, W. (1932) Of the words character and personality, *Character Personality*, **1**, 3 – 16.
- McKelvey, B. and Sekaran, U. (1977) Towards a career-based theory of job involvement: A study of scientists and engineers, *Administrative Science Quarterly*, **22**, 281 – 305.
- Mount, M. and Ilies, R. (2006) Relationship of personality traits and counterproductive work behaviors: the mediating effects of job satisfaction, *Personnel Psychology*, **59**, 591 – 622.
- Mudrack, P.E. (2004) Job involvement, obsessive-compulsive personality traits, and workaholic behavioral tendencies, *Journal of Organizational Change Management*, **17**, 490 – 508.
- Newton, T.J. and Keenan, A. (1983) Is work involvement an attribute of the person or the environment, *Journal of Occupational Behavior*, **4**, 169 – 178.
- Niehoff, B.P. (2006) Personality predictors of participation as a mentor, *Career Development International*, **11**, 321 – 333.

- O'Connor, B.P. (2002) A quantitative review of the comprehensiveness of the Five-Factor model in relation to popular personality inventories, *Assessment*, **9**, 188-203.
- Organ, D.W. and Lingl, A. (1995) Personality, satisfaction, and organizational citizenship behavior, *Journal of Social Psychology*, **135**, 339 – 350.
- Rabinowitz, S., Hall, D.T. and Goodale, J.G. (1977) Job scope and individual differences as predictors of job involvement: Independent or interactive, *Academy of Management Journal*, **20**, 273 – 281.
- Rabinowitz, S. and Hall, D.T. (1977) Organizational research on job involvement, *Psychological Bulletin*, **84**, 265 – 288.
- Small and Medium Enterprise Administration (2008) The White Paper on small and medium enterprises. http://book.moeasmea.gov.tw/book/doc_detail.jsp?pub_SerialNo=2008A00937&click=2008A00937 (accessed May 6, 2009).
- Smither, J.W., London, M. and Richmond, K.R. (2005) The relationship between leaders' personality and their reactions to and use of multisource feedback: A longitudinal study, *Group and Organization Management*, **30**, 181 – 210.
- Smithikrai, C. (2007) Personality traits and job success: An investigation in a Thai sample, *International Journal of Selection and Assessment*, **15**, 134 – 138.
- Stewart, G.L. and Nandkeolyar, A.K. (2006) Adaptation and intraindividual variation in sales outcomes: Exploring the interactive effects of personality and environmental opportunity, *Personnel Psychology*, **59**, 307 – 332.
- Tupes, E.C. and Christal, R.E. (1961) *Recurrent personality factors based on trait rating*, Report ASD-TR-61-97, Lackland Air Force Base, TX: U. S. Air Force.
- Varca, P.E. (2004) Service skills for service workers: Emotional intelligence and beyond, *Managing Service Quality*, **14**, 457 – 467.
- Wallace, J.C. and Vodanovich, S.J. (2003) Workplace safety performance: Conscientiousness, cognitive failure, and their interaction, *Journal of Occupational Health Psychology*, **8**, 316 – 327.
- Wallace, C. and Chen, G. (2006) A multilevel integration of personality, climate, self-regulation, and performance, *Personnel Psychology*, **59**, 529 – 557.